

CHAPTER 10

SPIRITUAL ASSESSMENT: A REVIEW OF COMPLEMENTARY ASSESSMENT MODELS

David R. Hodge and Crystal R. Holtrop

Spiritual assessment is increasingly recognized as a fundamental dimension of service provision (Hodge & Limb, 2010a). Despite this fact, most social workers appear to have received minimal training on the topic (Canda & Furman, 2010; Sheridan, 2009). The lack of attention devoted to spiritual assessment represents a significant oversight. To highlight the importance of spiritual assessment, we will briefly discuss four rationales related to ontology, ethics, strengths, and autonomy.

Spirituality is often central to clients' personal ontology. In other words, spirituality can be the essence of their personhood, the lens through which they view reality. Accordingly, spirituality may inform attitudes and practices in many areas, including child rearing, communication styles, diet, marriage arrangements, medical care, military participation, recreation, schooling, and social interactions (Hodge, 2004b; Van Hook, Hugen & Aguilar, 2001). For many individuals, religion is the most important facet of their lives (Newport, 2006). Further, for African Americans, women, the elderly, the poor, and many other populations of significance to social workers, spirituality is particularly salient (Newport, 2006; Smith & Faris, 2005; Taylor, Chatters & Jackson, 2007). The provision of respectful services to these groups is often contingent upon practitioners' awareness of clients' spiritually based beliefs and practices. In order to provide effective services, social workers must develop some understanding of clients' spiritual worldviews (Hodge & Bushfield, 2006).

A second rationale stems from the profession's ethical mandates. Spirituality is often expressed in distinct spiritual traditions or faith-based cultures (Van Hook et al., 2001). The NASW Code of Ethics (2008) stipulates that social workers are to demonstrate competence and sensitivity toward faith-based cultures (1.05b) and recognizes the strengths that exist among such groups (1.05a). Similarly, the NASW Standards for Cultural Competence in Social Work Practice (2001) recognize the importance of developing cultural competency in the area of spirituality and religion. In short, ethically sound practice entails obtaining the knowledge to exhibit spiritual sensitivity to clients.

Social workers are increasingly recognizing the importance of strengths (Saleebey, 2009; Smith, 2006). Reviews have consistently found a generally positive association between spirituality and a wide number of beneficial char-

acteristics (Koenig, McCullough & Larson, 2001; Koenig, 2007). More specifically, various measures of spirituality and religion have been associated with higher levels of well-being, happiness and life satisfaction; hope and optimism, purpose and meaning in life, self-esteem, marital stability and satisfaction, social support, and faster recovery from depression (Johnson, 2002; Koenig et al., 2001; Koenig, 2007). Unfortunately, these strengths often lie dormant. Spiritual assessment provides a vehicle to identify and tap clients' spiritual assets to help them in ameliorating their problems (Hodge, 2004b).

Finally, there is the issue of client autonomy. Many clients desire to integrate their spiritual beliefs and values into the helping relationship (Rose, Westefeld & Ansley, 2008). According to Gallup data reported by Bart (1998), 66% of the general public would prefer to see a professional counselor with spiritual values and beliefs and 81% wanted to have their own values and beliefs integrated into the counseling process. Further, research suggests that spirituality tends to become more salient during difficult situations (Ferraro & Kelley-Moore, 2000; Pargament, 2007), when individuals may be more likely to encounter social workers.

In sum, spiritual assessment provides social workers with a means to understand clients' spiritual strengths, beliefs, and values—in short—their worldview. Not only is such knowledge often critical for culturally competent practice, in many instances it is an ethical imperative. Spiritual assessment provides a mechanism to identify clients' spiritual resources and honor their desire to integrate their beliefs and values into the clinical dialogue.

In light of the importance of spiritual assessment, this chapter reviews a number of recently developed assessment approaches and provides examples of how they may be applied in practice with Christian clients. Our intent is not to provide an exhaustive review of various assessment methods, but rather to review a specific family of assessment instruments. These four instruments were developed to complement one another in the hopes of providing social workers with a set of assessment tools for use in numerous settings with a variety of clients. Rather than being interchangeable, one approach may be ideal in one context while another tool may be better suited to address a different client-to-practitioner interface. Readers are encouraged to obtain the original articles in which the instruments first appeared, which have since been collated into book form with added content (Hodge, 2003), and to become familiar with the strengths and limitations of each assessment instrument (Hodge & Limb, 2010b). The assessment tools may be used with clients from an array of different spiritual traditions. Recently, efforts have been made to validate each of the tools for use with Native American clients (Hodge & Limb, 2009a; Hodge & Limb, 2009b; Hodge & Limb, 2010c; Limb & Hodge, 2007; Limb & Hodge, 2011). In this chapter, however, we will be using Christian clients to illustrate the instruments.

After defining spiritual assessment, spirituality, and religion, four assessment instruments are reviewed—spiritual genograms (Hodge, 2001b), spiritual lifemaps (Hodge, 2005e), spiritual histories (Hodge, 2001a), and spiritual ecomaps (Hodge, 2000; Hodge & Williams, 2002). A brief overview of the assets and limitations of each method is provided and, for the three diagrammatic instru-

ments, case examples are supplied to familiarize the reader with the instrument. A brief discussion on conducting an assessment concludes the chapter.

Definitions

Spiritual assessment is defined as the process of gathering and organizing spiritually based data into a coherent format that provides the basis for interventions (Hodge, 2001a). The subsequent interventions may or may not be spiritually based. As implied above, a spiritual assessment may be conducted for the purposes of using traditional, non-spiritual interventions in a manner that is more congruent with clients' beliefs and values.

Spirituality is defined as an existential relationship with God (or perceived transcendence) (Hodge, 2001b). Religion flows from spirituality, expressing the spiritual relationship in particular beliefs, forms, and practices that have been developed in community with other individuals who share similar experiences of transcendent reality (Hodge, 2005d). Thus, in keeping with the understanding of many other social workers, spirituality and religion can be conceptualized as overlapping but distinct constructs (Canda & Furman, 2010; Hodge & McGrew, 2006).

Spiritual Genograms

In a manner analogous to traditional genograms, spiritual genograms provide social workers with a tangible graphic representation of spirituality across at least three generations (Hodge, 2001b). Through the use of what is essentially a modified family tree, they help both practitioners and clients understand the flow of historically rooted patterns through time. In short, spiritual genograms are a blueprint of complex intergenerational spiritual interactions.

In keeping with standard genogram conventions (McGoldrick, Gerson & Petry, 2008), the basic family structure is commonly delineated across at least three generations. Typically, squares represent males and circles denote females. In some cases, triangles or other geometric shapes can be used to designate individuals who have played major spiritual roles but are not members of the immediate biological family (Hodge, 2001b).

To indicate clients' spiritual tradition, colored drawing pencils can be used to shade in the circles and squares (Hodge, 2001b). Color coding provides a graphic "color snapshot" of the overall spiritual composition of the family system. Various colors can be used to signify religious preference (Buddhist, Christian, Hindu, Jewish, Muslim, New Age, none, etc.), or more specifically, when the information is known, denomination (Assemblies of God, Brethren, Catholic, Southern Baptist, Presbyterian, etc.). For example, a circle representing a female Southern Baptist could be colored red, a member of the Assemblies of God might be colored orange, a Muslim might be colored brown, and an individual whose affiliation and beliefs are unknown could be left uncolored. A change in an adult's religious orientation can be signified by listing the date

of the change beside a circle which is drawn outside the figure and filling in the space between the circle and the figure with the appropriate color, a procedure which indicates the stability or fluidity of the person's beliefs over time. Using a similar approach, changes in orientation might also be noted by coloring the vertical segment connecting the child with the parents.

If needed, the color scheme can also be used to incorporate information on commitment (devout vs. nominal) and theology (conservative vs. liberal) (Hodge, 2001b). For example, yellow might be used to signify a devout, conservative Methodist while gray could be used for a nominal Methodist. Alternatively, symbols, which are placed beside the appropriate circle or square, could be used to indicate the degree of commitment or theological orientation. An open set of scriptures, for instance, might be used to indicate a devout person. Social workers can explain the options to clients and allow them to select the colors and symbols that they perceive best express their worldview.

Spiritually meaningful events can also be incorporated, such as water and spirit baptisms, confirmations, church memberships, and bar mitzvahs (Hodge, 2001b). Symbols drawn from the client's spiritual journey can be used to signify these events. For instance, a cross might be used by a Christian to indicate reaching a point of conversion, a dove might be used by a Pentecostal to depict a deeper work of the Holy Spirit, or a sunbeam might be used by a New Age adherent to symbolize a time of profound spiritual enlightenment. In addition, short summary statements can be used to denote significant events or personal strengths.

In addition to depicting religious beliefs, it is also possible to include an affective component (Hodge, 2005c). In other words, felt spiritual closeness between family members can be illustrated on spiritual genograms. Lines with double-headed arrows can be used to symbolize a relationship in which individuals experience a close reciprocal spiritual bond. The thickness of the line can indicate the intimacy or strength of the relationship. In situations where the relationship is more hierarchical and less reciprocal—as might occur with a grandparent mentoring a grandchild—a single arrowhead can be used to depict the flow of spiritual resources. Finally, spiritual conflict can be portrayed with a jagged line, similar to a lightning bolt, drawn between the two individuals.

Case Example

Diagram 1 (following page) indicates what a relatively straightforward spiritual genogram might look like for a couple, Mark and Beth, who are experiencing marital problems. In place of the colors that would normally be used with a spiritual genogram, patterns (for example, dots, diagonals, waves) are employed to depict various denominations.

After three years of marriage, Mark, 26, and Beth, 23, requested counseling after the recent birth of their daughter, Megan. Her birth renewed their interest in church attendance as they both desired to have Megan baptized and raised with spiritual values. However, they disagreed on practically everything else—

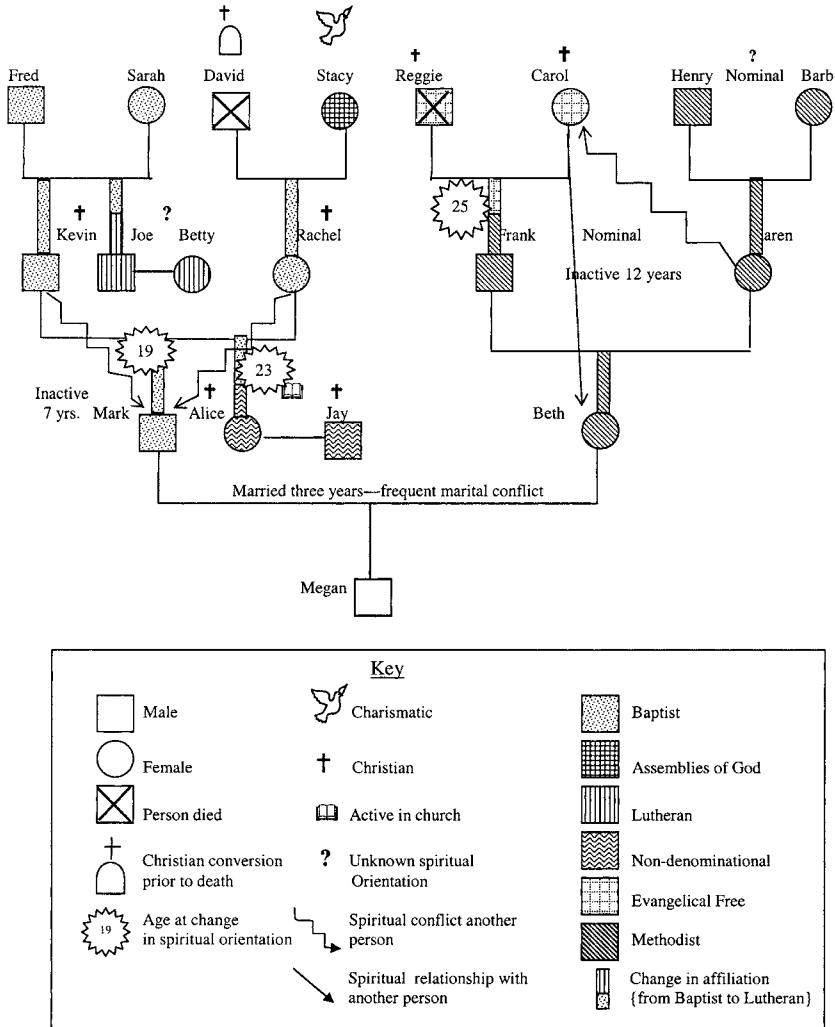

Diagram 1.

how to spend money, parent their daughter, where to go to church, and how to accomplish household tasks. Mark and Beth's inability to resolve conflict was due to a power struggle over whose family of origin's rules they were going to follow. Due to their conflict over which church to attend, the therapist developed a spiritual genogram to enhance their traditional genogram.

During Mark's childhood, his nuclear family and his paternal grandparents attended the Baptist church that was 3 blocks away from their house. His family shared a tradition of going to Mark's paternal grandparents' house every Sunday after church. Although Mark knew that Aunt Betty and Uncle Joe attended a

Lutheran church regularly, he had never heard them talk openly about their faith at family gatherings and was unsure how important it was to them. His maternal grandmother attended an Assemblies of God church before she was placed in the nursing home. He recalled his grandmother sharing a story about how she prayed for 30 years that her husband would become a Christian, and that her prayers were answered shortly before her husband died.

During his adolescence, Mark perceived his parents' rules as old-fashioned and rigid and rebelled against them. As soon as he left home, Mark stopped attending church, much to his parents' chagrin. His sister, Alice, left the Baptist church when she was 23 years old and started attending a non-denominational church where she met her husband, Jay. Alice and Jay are still actively involved in this church and frequently share information with Mark and Beth about family activities that are occurring there. As Mark shared this information, the therapist drew a cross by the names of his parents, paternal grandparents, maternal grandmother, sister, and brother-in-law to indicate that they were Christians. She put a question mark next to his aunt and uncle due to Mark's lack of clarity about their level of commitment to their faith. In order to signify Alice and Jay's devout faith and active participation in their church, the therapist drew an open Bible near their names. She colored their circles and squares different colors to indicate the various denominations represented in Mark's family. Uncle Joe's and Alice's rectangles that attach them to their respective parents have two colors, indicating that they switched from attending the Baptist church to a different denomination.

Beth's family attended a Methodist church when she was young. However, their attendance dwindled to Easter and Christmas as Beth became active in school activities. She knew that her parents both believed in God, but did not see this belief influencing their lives. However, Beth had fond memories of sitting on her paternal grandmother's lap as she listened to her grandmother, Carol, read Bible stories to her. She also recalled attending Vacation Bible school which was sponsored by the Evangelical Free church her grandmother attended. She assumed that "Grandma Carol" was a committed Christian because she overheard her mother complain about "how religious Grandma Carol was" and observed her mother rebuff Grandma Carol whenever she offered to pray for the family. To signify Beth's mother's underlying conflict towards Grandma Carol over spiritual matters, the therapist drew a jagged arrow between their circles. Although her paternal grandfather died before Beth was born, she recalled her Grandma Carol fondly referring to her husband as "a fine man who loved people and the Lord."

Although Beth stated she believes in God, she acknowledged that she presently refers to God primarily when she is swearing angrily at Mark. However, as the conflict between Beth and Mark continued to escalate, she started contemplating "giving God a try." She was open to attending a church as long as it was not Mark's parents' church. She thought his mother already interfered with their marriage far too much. The therapist colored Beth's maternal grandparents' and parents' circles and squares red to represent the Methodist denomination. Due to their nominal interest in spiritual matters, Beth and Mark agreed that

the therapist should not draw a cross by their names. She did draw a cross by Grandma Carol's name and by her paternal grandfather's name, and also drew an arrow from her Grandmother Carol to Beth, indicating the spiritual influence she had on Beth.

With the multi-colored spiritual genogram directly in front of them, Mark and Beth were struck by the diversity of denominations represented in their extended families. This new perspective helped them see beyond their original, narrowly defined choices of Baptist vs. Methodist that Mark and Beth clung to out of loyalty to their families of origin. The therapist encouraged the couple to interview members of their extended family, asking questions concerning their faith, their religious practices, and the strengths and limitations of their church and denomination. Beth and Mark discovered that the new perspectives gained from the interviews helped them be more evaluative in their decision-making process and moved them beyond their stalemate.

Assets and Limitations

Although spiritual genograms can be effective assessment instruments in a number of situations, they may be particularly useful when the family system plays an important role in the client's life or when the client presents with problems involving family members or family of origin issues (Hodge, 2005a). For example, spiritual genograms might be used with interfaith couples experiencing spiritually based barriers to intimacy to expose areas of difference and potential conflict as well to highlight the respective spiritual strengths each person brings to the relationship. Similarly, spiritual genograms could also be used with couples from similar backgrounds to increase their level of intimacy.

Conversely, spiritual genograms may be an inappropriate assessment instrument in situations where historical influences are of minor importance (Hodge, 2005a). Further, even in situations where generational influences are pertinent, many clients do not connect past events with current difficulties. Accordingly, clients may view genogram construction and between-session tasks as an ineffective use of time. Proceeding with such interventions before clients appreciate their usefulness can reduce treatment adherence and jeopardize outcomes. Consequently, in some contexts it may be best to use assessment approaches that do not focus on the generational aspects of spirituality.

Spiritual Lifemaps

While spiritual genograms chart the flow of spirituality across at least three generations, spiritual lifemaps depict clients' personal spiritual life-story (Hodge, 2005e). More specifically, spiritual lifemaps are a pictorial delineation of a client's spiritual journey. In a manner analogous to renowned African writer Augustine's (354-430/1991) *Confessions*, spiritual lifemaps are an illustrated account of clients' relationship with God over time—a map of their spiritual life.

At its most basic level, a drawing pencil is used to sketch various spiritu-

ally significant life events on paper (Hodge, 2005e). The method is similar to various approaches drawn from art and family therapy in which a client's history is depicted on a "lifeline" (Tracz & Gehart-Brooks, 1999). Much like road maps, spiritual lifemaps tell us where we have come from, where we are now, and where we are going.

To assist clients in the creative expression of their spiritual journeys, it is usually best to use a large sheet of paper (e.g., 24" x 36") on which to sketch the map (Hodge, 2005e). Providing drawing instruments of different sizes and colors are also helpful as is offering a selection of popular periodicals and various types and colors of construction paper. Providing these items, in conjunction with scissors, glue sticks, and rulers, allows clients to clip and paste items onto the lifemap.

Spiritually significant events are depicted on a path, a roadway, or a single line that represents clients' spiritual sojourn (Hodge, 2005e). Typically, the path proceeds chronologically, from birth through to the present. Frequently the path continues on to death and the client's transition to the afterlife. Hand drawn symbols, cut out pictures, and other representations are used to mark key events along the journey. In keeping with many spiritual traditions, which conceive material existence to be an extension of the sacred reality, it is common to depict important lifestage events on the lifemap (for example, marriage, birth of a child, death of a close friend or relative, or loss of a job). While it is often necessary to provide clients with general guidelines, client creativity and self-expression should typically be encouraged.

To fully operationalize the potential of the instrument, it is important to ask clients to incorporate the various crises they have faced into their lifemaps along with the spiritual resources they have used to overcome those trials (Hodge, 2005e). Symbols such as hills, bumps, potholes, rain, clouds, and lightning can be used to portray difficult life situations. Delineating successful strategies that clients have used in the past frequently suggests options for overcoming present struggles.

Case Example

Diagram 2 (following page) provides an example of what a spiritual lifemap might look like on a smaller scale. Tyrone, a 42 year-old black male, was recently diagnosed with terminal cancer. The doctor confirmed his worst fears that the cancer was inoperable, and predicted that Tyrone had approximately 6 months to live. A medical social worker on the oncology ward met with Tyrone to help him process the shock of his prognosis and prepare for what appeared to be a premature death. Shortly into their conversation, the social worker discovered that Tyrone was actively involved in the Third Missionary Baptist Church. Tyrone's eyes lit up as he shared that he began playing guitar in the church's music ministry 10 years ago, a couple of years after he became a Christian. It soon became clear to the social worker that Tyrone's faith was a significant strength and could help him cope with his present crisis. In order to help Tyrone identify

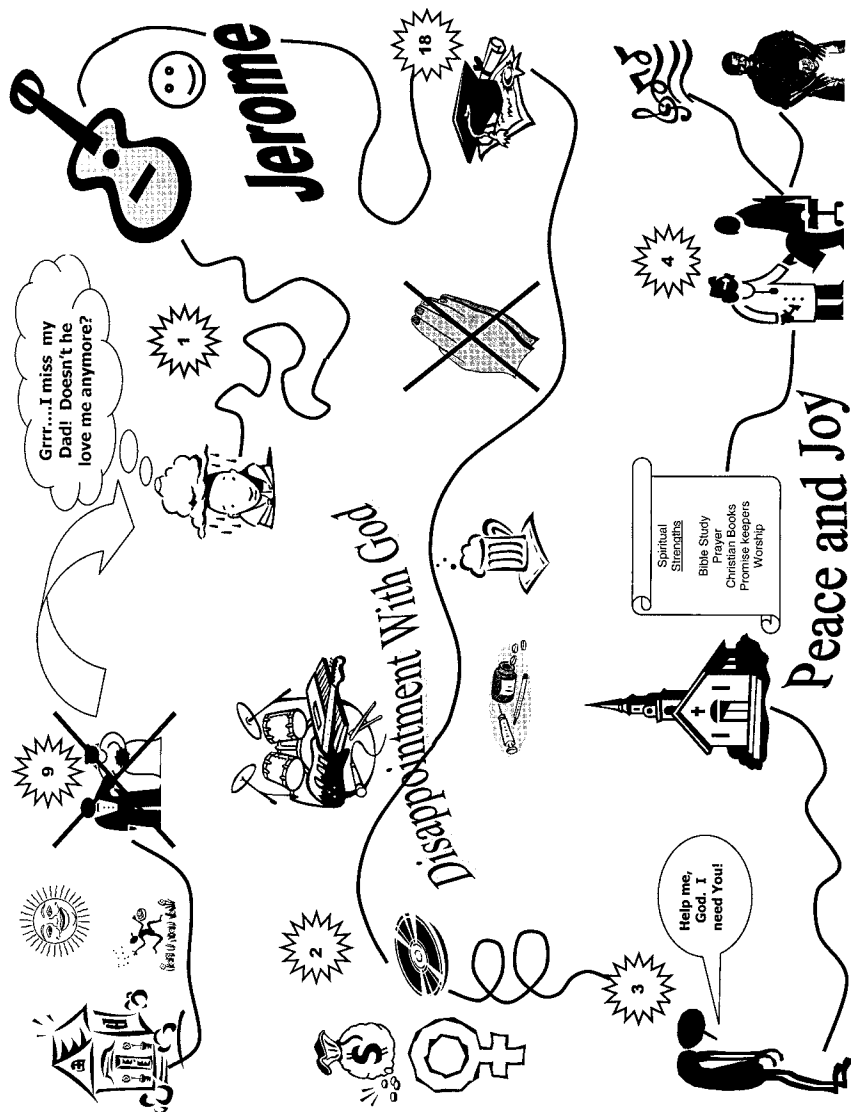

Diagram 2.

effective coping strategies, the social worker encouraged Tyrone to develop a spiritual lifemap. Tyrone's creativity and musical interests seemed to indicate that this assignment would be a good fit for his personality.

Tyrone's parents divorced when he was 9 years old. He and his 2 older sisters lived with his mother and periodically visited his father. His mother was actively involved in a Pentecostal church and sang in the church choir. When Tyrone reached adolescence, his anger toward his absent father began to

mount and was acted out in rebellion toward his mother. Out of desperation, his mother arranged guitar lessons for Tyrone to creatively redirect his anger and build his self-esteem. Tyrone established a lifelong mentoring relationship with his guitar teacher, Jerome, who consistently believed in him and spawned a passion for a variety of musical styles including blues, jazz, gospel, and rock. When he graduated from high school, he joined a band and played in clubs for the next 9 years. Disillusioned with God for not answering his childhood prayers for his father, Tyrone started experimenting with drugs and alcohol to numb his emptiness inside.

By age 27, Tyrone had successfully recorded a CD with his band and was gaining local notoriety. Life was good. He was doing well financially and he enjoyed dating several different women. However, this season was short-lived. By age 30, he was significantly in debt and was emotionally broken. After 3 years of dating, Tyrone's girlfriend, Janet concluded that Tyrone was more committed to his band than to her and she broke up with him. He coped by increasing his alcohol consumption, which hurt his performance and created conflict with his band members. After a particularly heated argument, Tyrone sought solace from Jerome, his former guitar teacher. Through this renewed friendship, Tyrone began examining his life, his priorities, and the source of his emptiness and bitterness. He forgave God for what he perceived to be abandonment (a replication of his father's abandonment) and he experienced a profound sense of God's love and acceptance. Tyrone soon realized that it was he, not God, who had abandoned divine and human love out of bitterness and despair.

Tyrone started attending the Third Missionary Baptist church. Upon Jerome's advice, Tyrone took a break from playing guitar and immersed himself in Bible study, prayer, and Christian books to help him sort out his unresolved hurts, develop effective anger management skills, and evaluate his life goals. He also developed significant relationships with other men in a Promise Keepers group. He watched several men in the group weather severe trials by clinging onto God's promises and by receiving love and support from their friends. He gradually learned that no matter what happens in life, God is good, faithful, and in control. After a 2-year hiatus, Tyrone began playing guitar in church. Using his talents to worship God gave him a sense of meaning and joy that was deeper than any he had experienced before. Completing the spiritual lifemap helped Tyrone reflect on his life, his pit and peak experiences, the lessons he had learned, and the people who had blessed him. Most importantly, he identified key people that would support him through his present illness and pray for God to heal him. While discussing the lifemap with his social worker, Tyrone began to clarify the goals he still wanted to accomplish, like mentoring some young boys in church who were growing up in single parent homes. Through this reflective assignment, he also made the decision to write some songs as a creative way to express his pain, cry out to God, and receive strength and comfort.

Assets and Limitations

Of the assessment methods reviewed in this chapter, spiritual lifemaps are perhaps the most client-directed. Consequently, there are a number of unique advantages associated with the use of this diagrammatic model (*Hodge, 2005a*). By placing a client-constructed media at the center of assessment, the message is implicitly communicated that the client is a competent, pro-active, self-directed, fully engaged participant in the therapeutic process. Additionally, individuals who are not verbally oriented may find pictorial expression more conducive to their personal communication styles.

The relatively secondary role that social workers play during assessment also offers important advantages (*Hodge, 2005a*). For many clients, spirituality is a highly personal, sensitive area. Most social workers have had limited training about various spiritual worldviews, in spite of the central role spirituality plays in human behavior (*Canda & Furman, 2010; Sheridan, 2009*). Consequently, there is the distinct risk that social workers may offend clients and jeopardize the therapeutic relationship through comments that are inadvertently offensive, especially with the use of more practitioner-centered, verbally-based assessment approaches. The pictorial lifemap affords practitioners the opportunity to learn more about the client's worldview while focusing on building therapeutic rapport by providing an atmosphere that is accepting, nonjudgmental, and supportive during assessment (*Hodge, 2005e*).

In terms of limitations, some social workers may feel so removed from the process that this assessment approach makes poor use of therapeutic time (*Hodge, 2005a*). Indeed, in the time-constrained, managed care world in which many practitioners work, in some cases it may be advisable to use the lifemap as a homework assignment (*Hodge, 2005e*). Another significant limitation is that many clients, such as those who are more verbal, those that are uncomfortable with drawing, or those who prefer more direct practitioner and client involvement, may find the use of a largely non-verbal, pictorial instrument to be a poor fit.

Spiritual Histories

A spiritual history represents a narrative alternative to a spiritual lifemap (*Hodge, 2001a*). Instead of relating the client's spiritual sojourn in a diagrammatic format, the client's spiritual story is related verbally. In a process that is analogous to conducting a family history, the client is provided an interactive forum to share his or her spiritual life story.

To guide the conversation, a two-part framework is used (*Hodge, 2001a*). As can be seen in Table 1, the first part consists of an initial narrative framework. The purpose of these questions is to provide practitioners with some tools for structuring the assessment. The aim is to help clients tell their stories, typically moving from childhood to the present.

It should also be noted that the questions delineated in Table 1 are offered as suggestions (*Hodge, 2001a*). Social workers should not view them as a rigid

Table I. Guidelines for conducting spiritual histories

Initial Narrative Framework

1. Describe the religious/spiritual tradition you grew up in. How did your family express its spiritual beliefs? How important was spirituality to your family? Extended family?
2. What sort of personal experiences (practices) stand out to you during your years at home? What made these experiences special? How have they informed your later life?
3. How have you transitioned or matured from those experiences? How would you describe your current spiritual/religious orientation? Is your spirituality a personal strength? If so, how?

Interpretive Anthropological Framework

1. Affect: What aspects of your spiritual life give you pleasure? What role does your spirituality play in handling life's sorrows? Enhancing its joys? Coping with its pain? How does your spirituality give you hope for the future? What do you wish to accomplish in the future?
2. Behavior: Are there particular spiritual rituals or practices that help you deal with life's obstacles? What is your level of involvement in faith-based communities? How are they supportive? Are there spiritually encouraging individuals that you maintain contact with?
3. Cognitive: What are your current religious/spiritual beliefs? What are they based upon? What beliefs do you find particularly meaningful? What does your faith say about trials? How does this belief help you overcome obstacles? How do your beliefs affect your health practices?
4. Communion: Describe your relationship to the Ultimate. What has been your experience of the Ultimate? How does the Ultimate communicate with you? How have these experiences encouraged you? Have there been times of deep spiritual intimacy? How does your relationship help you face life challenges? How would the Ultimate describe you?
5. Conscience: How do you determine right and wrong? What are your key values? How does your spirituality help you deal with guilt (sin)? What role does forgiveness play in your life?
6. Intuition: To what extent do you experience intuitive hunches (flashes of creative insight, premonitions, spiritual insights)? Have these insights been a strength in your life? If so, how?

template that must be applied in every situation, but rather as a fluid framework that should be tailored to the needs of each individual client. In other words, the questions provide a number of possible options that can be used to facilitate the movement of the narrative and to elicit important information.

The second part of Table 1 consists of an interpretive framework (Hodge, 2001a) based on the anthropological understandings of Chinese spirituality writer Watchman Nee (1968). In addition to soma, Nee envisions a soul, comprised of affect, will, and cognition, and a spirit, comprised of communion, conscience, and intuition. Although human beings are an integrated unity and, consequently, the six dimensions interact with and influence one another, it is possible to distinguish each dimension. As is the case with other human dimensions, such as affect, behavior, and cognition, the dimensions of the spirit also can be discussed individually.

Communion refers to a spiritually based relationship (Nee, 1968). More specifically, it denotes the ability to bond with and relate to God. Conscience relates to one's ability to sense right and wrong. Beyond a person's cognitively held values, conscience conveys moral knowledge about the appropriateness of a given set of choices. Intuition refers to the ability to know—to come up with insights that by-pass cognitively based, information-processing channels.

As is apparent in Table 1, the questions in the interpretive anthropological framework are designed to elicit information about each of the six dimensions. The questions are not meant to be asked in any specific order. Rather, they are provided to help social workers draw out the richness of clients' spiritual stories. As clients relate their spiritual narrative, they may tend to touch upon some of the dimensions listed in the interpretive anthropological framework. Social workers can pose questions drawn from the framework to more fully explore clients' spiritual reality in the natural flow of the therapeutic dialogue.

Assets and Limitations

There is some evidence that information is stored and organized as a narrative in the mind (Hodge, 2001a). Accordingly, assessment methods that are congruent with this reality work with, rather than against, clients' mental thought processes. Indeed, for verbally oriented persons, spiritual histories may provide the best assessment method. The non-structured format allows clients to relate their stories in a direct, unfiltered manner. For example, whereas genograms require clients to circumscribe their spiritual reality upon a generational chart, assessment with spiritual histories allows clients to choose the relevant material to be shared (Hodge, 2005a).

However, not all clients are verbally oriented and some may find that a narrative assessment places too much attention on them in light of the sensitive, personal nature of spirituality (Hodge, 2005a). Some clients find it helpful to have a specific framework. Given the amorphous, subjective nature of spirituality, physical depiction may help concretize the client's strengths (Hodge, 2000). In other words, the process of conceptualizing and depicting one's spiritual journey

may help to focus and objectify spiritual assets, which can then be discussed and marshaled to address problems. Still another limitation is the time spent exploring portions of the client's spiritual history that may have limited utility in terms of addressing the present problem the client is wrestling with.

Spiritual Eco-maps

In contrast to the above assessment tools, spiritual eco-maps focus on clients' current spiritual relationships (Hodge, 2000; Hodge & Williams, 2002). The assessment instruments previously mentioned are united in the sense that they all are designed to tap some portion of a client's spiritual story as it exists through time. Spiritual genograms, lifemaps and histories typically cover one to three generations of a client's spiritual narrative. Spiritual eco-maps, on the other hand, focus on that portion of clients' spiritual story that exists in space. In other words, this assessment approach highlights clients' present relationships to various spiritual assets.

In keeping with traditional eco-gram construction (Hartman, 1995) the immediate family system is typically portrayed as a circle in the center of a piece of paper. Household family members can be sketched inside the circle, with squares depicting males and circles representing females (Hodge, 2000). Alternatively, separate eco-maps can be drawn for each individual (Hodge & Williams, 2002).

Significant spiritual systems or domains are depicted as circles on the outskirts of the paper, with the names of the respective systems written inside the circles. The circles are placed in a radius around the family circle, which may consist of a single figure representing the client. While clients should be encouraged to depict the domains that are most relevant to their spiritual worldviews, there are a number of spiritual systems that are strengths across many spiritual traditions.

More specifically, social workers should generally seek to explore clients' relationships with God, rituals, faith communities and encounters with angels, demons, and other spiritual visitations (Hodge, 2000). One's relationship with God is widely regarded as a key strength, as are rituals, or codified spiritual practices such as devotional reading, meditation, prayer, scripture study, singing hymns, worship, "practicing the presence" of God by focusing on God's presence and active involvement in daily affairs. Faith communities refer to various church and para-church communities that individuals may associate with on a regular basis, such as church services, fellowship groups, mid-week Bible studies, youth groups, and singles associations.

As suggested above, social workers should also seek to incorporate into the eco-map any spiritual system that has meaning to the client (Hodge, 2000). For example, one may wish to explore clients' relationship to their parents' spiritual traditions or their relationship to individuals who hold a position of significant spiritual leadership in their lives, such as a pastor, spiritual mentor, or elder. The goal should be to delineate on the eco-map all the spiritual systems that are relevant to the client's present spirituality.

The heart of the spiritual eco-map is the depiction of relationships between the family system and the spiritual systems, which are represented by various types of sketched lines (Hodge, 2000). Thicker lines represent stronger or more powerful relationships. A dashed line represents the most tenuous relationship, while a jagged line denotes a conflicted one. An arrow is drawn on the line to indicate the flow of energy, resources, or interest. As is the case with the other diagrammatic instruments profiled above, short, descriptive encapsulations, significant dates, or other creative depictions, can also be incorporated onto the map to provide more information about relational dynamics.

When using eco-maps with individuals, the appropriate type of line is drawn in between the family system (the figure representing the client) and the spiritual systems. When working with families, lines are drawn to the family system as a unit when the family shares a particular relationship in common, or more frequently, connections are drawn to individual family members depicting the various unique relationships between each family member and various spiritual systems.

A Case Example

In an abbreviated manner, Diagram 3 depicts how a spiritual eco-map might be used with the Martinez family, consisting of Miguel and Maria, and their two children, Angie, 16, and Tony, 10. The Martinez family sought counseling as part of a relapse prevention plan for Angie who had recently been released from an in-patient alcohol treatment program. The goal of counseling was to reduce the conflict and distrust that existed between Angie and her parents. Angie thought her parents were overly strict, and her parents felt betrayed by Angie's chronic lying. In addition, Miguel and Maria removed Angie from public school and enrolled her in a Christian school in an attempt to prevent her from associating with her peer group that frequently abused alcohol.

Angie and her parents were embroiled in a heated conflict as Angie complained that the Alcoholic's Anonymous (AA) groups that her parents insisted she attend were "stupid and a waste of time." Due to Angie's prior deceitfulness and poor decision-making, her parents did not trust Angie's assessment of the AA groups and were adamant that she needed to continue attending two groups per week to help her maintain her sobriety. In order to address this dilemma, the therapist developed a spiritual eco-map with the family to explore the family's spiritual worldview and resources and identify spiritually based alternatives to AA attendance. The family was receptive to this because AA had substantiated the benefits of spirituality in treating alcoholism.

The Martinez family was currently attending St. Vincent's parish. Maria had grown up in this parish and knew many of the parishioners. She and Miguel had attended Cursillo, a weekend retreat that guided participants as they explored a deeper relationship with God, and they continued to participate in Cursillo's on-going groups. Maria, in particular, stated that she had received a great deal of support and prayer from this group when she and Miguel discovered Angie's struggle with alcoholism. Tony had been an altar boy for a couple years and looked

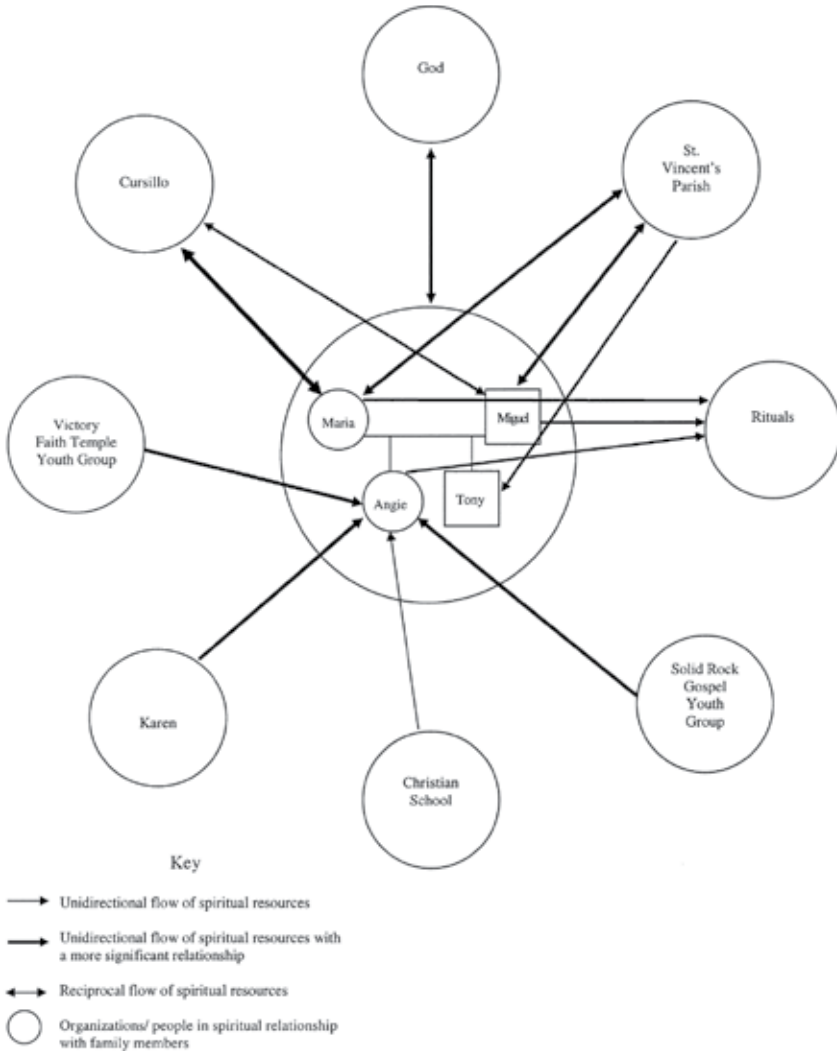

Diagram 3.

forward to seeing his friends at his Christian education class. In the past, Angie had viewed attending mass with disdain and thought that her peers at their parish were “stale.” However, after attending in-patient treatment and switching to the Christian school, Angie slowly began to develop an interest in spirituality. Upon invitation from her new friends at school, Angie attended several local youth groups. Specifically, she enjoyed the “cool music” at Solid Rock Gospel Church, and liked the youth pastor, Dan, and his wife, Karen, at Victory Faith Temple. The therapist asked Miguel and Maria if they would be comfortable replacing the AA groups with the youth groups. Although they both wished Angie would

attend the Catholic youth group at their parish, they agreed to give it a try and the family contracted to evaluate the youth groups' effectiveness in two months.

The therapist asked the Martinez family if they practiced any family rituals at home. Maria stated that she and Miguel each individually spent some time reading scripture and praying. Angie surprised her parents by stating that, after a conversation with Karen, she had recently started reading a devotional book when she felt upset and praying when she felt tempted to drink. Miguel shared that they discontinued their attempt at family devotions a year ago after a major fight arose between Angie and him. The therapist asked if they would be interested in initiating family devotions again. However, in order to break the conflict pattern of the parents lecturing and Angie bristling at their rigid rules, the therapist encouraged structuring the family devotional time as an open forum in which all family members would be free to share their perspectives and struggles. Miguel and Maria might share how their faith guides their decision-making and helps them deal with life's pain and hardships. Angie and Tony might share what they were learning in youth group, school, and Christian education class. This weekly ritual could potentially reassure Miguel and Maria that Angie was learning productive coping skills, build trust between family members, and help them forgive past grievances.

In congruence with the AA model, the therapist asked Angie if she could identify anyone on the spiritual eco-map that she respected and would like to be her sponsor who would provide support, guidance, and accountability for her. Angie stated that Karen had shared her life story in youth group, and was sure that Karen would be understanding, nonjudgmental, and helpful to her.

By developing the spiritual eco-map, the therapist was able to use the Martinez family's current spiritual resources to help them identify new solutions to their problems. Before this counseling session, Miguel and Maria had briefly heard Angie mention Karen's name, but their distrust and concern that the youth groups were not Catholic had prevented them from hearing the positive influence Karen and the groups were having in Angie's life. The process of developing the spiritual eco-map allowed Angie to openly share for the first time that her new-found faith was helping her stay sober and that the youth groups were helping her grow spiritually. As a result, the family moved past their stalemate, broke down barriers to communication, and began establishing trust.

Assets and Limitations

The main asset of spiritual eco-maps is that they focus upon clients' current spiritual strengths (*Hodge, 2005a*). For social workers seeking to operationalize clients' spiritual assets to help clients solve their problems, this assessment approach may be ideal. The time spent in assessment is focused upon tapping into present spiritual resources.

In some cases, clients may find it less threatening to have a concrete object that functions as the focus of subsequent conversation. As is the case with all diagrammatic instruments, spiritual eco-maps provide an object that can serve

as the focal point of discussion. The design of eco-maps, however, with their focus on environmental systems rather than, for example, clients' life stories, helps remove the emphasis from the client as an individual. In short, while other approaches may implicitly emphasize clients, devoid of their contexts, spiritual eco-maps explicitly stress the spiritual systems in clients' environments (Hodge, 2005a).

Spiritual eco-maps suffer from the same limitations as other diagrammatic instruments relative to verbally based spiritual histories. In addition, in at least some situations, the focus on current spiritual assets may result in a limited assessment that overlooks salient historical factors. In some contexts, social workers may wish to explore historical resources by using, for example, a spiritual genogram.

Conducting an Assessment

Knowledge of how to conduct an assessment is also important (Hodge & Limb, 2010a). Developing familiarity with various assessment tools is only part of the assessment process. Practitioners must also know how to use these tools in an appropriate, spiritually sensitive manner. Although a detailed discussion of the mechanics of conducting a spiritual assessment is beyond the scope of this chapter, a few important points will be highlighted.

Social workers should be aware that many clients may be hesitant to trust practitioners. Some clients may be concerned that practitioners will not treat with honor that which is held to be sacred (Richards & Bergin, 2000). Consequently, due to the highly personal nature of spirituality, it is appropriate to procure clients' consent before engaging in a spiritual assessment (Hodge, 2006). Additionally, social workers should explain a particular assessment instrument to ensure that the client is comfortable with the particular approach before engaging in an assessment.

To a great extent, clients' apprehension can be alleviated by expressing genuine support. Adopting an attitude of interest and curiosity toward the client's belief system is an appropriate therapeutic stance (Patterson, Hayworth, Turner & Raskin, 2000).

Social workers can also demonstrate spiritual sensitivity by obtaining knowledge of common spiritual traditions (Hodge, 2005b). For example, if one works in an area where Latter Day Saints and Pentecostals are prominent spiritual traditions, then seeking out information on LDS (Ulrich, Richards & Bergin, 2000) and Pentecostal traditions (Dobbins, 2000) can assist social workers in exhibiting spiritual sensitivity with these populations. Ideally, in the process of attempting to understand clients' spiritual worldviews, social workers should seek to envision life through the particular worldview of the client (Hodge, 2004a).

In their attempts to understand the worldviews of clients, social workers should develop their understanding of the oppression people of faith often experience in the larger secular culture (Smith, 2003). It is important for social workers to recognize that the dominant secular culture often marginalizes or oth-

erwise de-legitimizes devout faith in many influential settings, such as network news (Kerr, 2003), fictional television (Clarke, 2005), colleges and universities (Cnaan, Wineburg & Boddie, 1999; Hodge, Baughman & Cummings, 2006; Rothman, Lichter & Nevitte, 2005) and other cultural-shaping “knowledge sector” forums (Hunter, 1991). In other words, people who are secular experience a certain privilege that is foreign to people of faith (Hodge, 2009). Social workers should reflect on how living in a culture that often ignores, devalues, and even ridicules believers’ most cherished beliefs and values affects the psychology of people of faith (Ressler & Hodge, 2003).

Developing their understanding of clients’ worldviews can assist social workers in respecting clients’ spiritual autonomy. The focus of practice should not be on determining whether clients’ spiritual beliefs are right or wrong, but rather on how their values animate their lives and assist them in coping with difficulties. The social worker’s job is not to accept or reject clients’ spiritual values but to understand them and help them use their beliefs and practices to assist clients in overcoming their problems (Hodge, 2006).

In some cases, however, social workers may believe that clients’ spiritual beliefs are problematic. In such situations, social workers should not attempt to change clients’ values in an area that lies outside the realm of their professional competence. Rather, practitioners should collaborate with or refer such clients to clergy (Gilbert, 2000). Given that this is the clergy’s area of professional competency, pastors, priests, and other spiritual specialists are better equipped to ascertain the appropriateness of a given set of beliefs and practices (Hodge, Bonifas & Chou, 2010). It is critical, however, that practitioners respect clients’ spiritual autonomy by forming collaborative relationships with clergy that share the same denominational and theological orientation as the client. It would be unethical to covertly attempt to subvert clients’ values by, for example, referring a client who holds traditional beliefs to a liberal pastor.

In keeping with their roles as social workers, practitioners should remain focused on empowering clients to address their problems. During the assessment process, social workers might keep two questions in mind. First, during past difficulties, how have clients culled from their spiritual frameworks various resources to address previous problems? Second, what types of unaccessed resources are available in this framework that can be marshaled to address current problems? Social workers can attempt to link clients with untapped resources to help them solve their problems. Practitioners might, for example, suggest particular interventions either drawn from, or consistent with, clients’ spiritual worldviews.

More specifically, social workers might employ a modified form of cognitive therapy in which unhealthy beliefs are identified and replaced with positive beliefs drawn from the individual’s spiritual belief system (Hodge, 2008). Similarly, practitioners may explore the possibility of reframing current problems as opportunities for spiritual growth (Jankowski, 2002; Pargament, 2007). In attempting to foster the adoption of more productive patterns of behaviors, spiritual rituals may be employed as “exceptions” to unproductive behavioral

patterns (Hodge, 2000). Decision-based forgiveness interventions may be useful in some contexts (DiBlasio, 1998) while existential, brevity of life interventions may be appropriate in other situations (Hodge, 2005e). Some evidence also suggests that intercessory prayer may assist clients in the recovery process (Hodge, 2007). In each individual setting, the unique spiritual beliefs of the clients and the theoretical orientation of the social worker will indicate which interventions are selected. In any setting, however, the goal should be to help clients use their spiritual strengths to address their issues and concerns.

Conclusion

In order to provide services that are sensitive to clients' spiritual worldviews, social workers must conduct spiritual assessments to have some awareness of clients' spiritual realities. Similarly, to help clients tap into their spiritual strengths to address the problems they wrestle with, it is necessary to undertake an assessment of clients' strengths. A single assessment approach, however, is unlikely to be ideal in all situations; diverse needs call for a variety of approaches. If the profession of social work is to take seriously its mandate to provide culturally sensitive services that build upon clients' unique strengths, then in many cases performing a spiritual assessment is an imperative.

References

- Augustine. (354-430/1991). *Confessions* (H. Chadwick, Trans.). New York: Oxford University Press.
- Bart, M. (1998, December). Spirituality in counseling finding believers. *Counseling Today*, 41(6), 1, 6.
- Canda, E. R., & Furman, L. D. (2010). *Spiritual diversity in social work practice: The heart of helping* (2nd ed.). New York: Oxford University Press.
- Clarke, S. H. (2005). Created in whose image? Religious characters on network television. *Journal of Media and Religion*, 4(3), 137-153.
- Cnaan, R. A., Wineburg, R. J., & Boddie, S. C. (1999). *The newer deal: Social work and religion in partnership*. New York: Columbia University Press.
- DiBlasio, F. A. (1998). The use of a decision-based forgiveness intervention within intergenerational family therapy. *Journal of Family Therapy*, 20(1), 77-94.
- Dobbins, R. D. (2000). Psychotherapy with Pentecostal Protestants. In P. S. Richards & A. E. Bergin (Eds.), *Handbook of psychotherapy and religious diversity* (pp. 155-184). Washington, DC: American Psychological Association.
- Ferraro, K. F., & Kelley-Moore, J. A. (2000). Religious consolation among men and women: Do health problems spur seeking? *Journal of the Scientific Study of Religion*, 39(2), 220-234.
- Gilbert, M. (2000). Spirituality in social work groups: Practitioners speak out. *Social Work with Groups*, 22(4), 67-84.
- Hartman, A. (1995). Diagrammatic assessment of family relationships. *Families in Society*, 76(2), 111-122.
- Hodge, D. R. (2000). *Spiritual ecomaps: A new diagrammatic tool for assessing marital*

- and family spirituality. *Journal of Marital and Family Therapy*, 26(1), 229-240.
- Hodge, D. R. (2001a). Spiritual assessment: A review of major qualitative methods and a new framework for assessing spirituality. *Social Work*, 46(3), 203-214.
- Hodge, D. R. (2001b). Spiritual genograms: A generational approach to assessing spirituality. *Families in Society*, 82(1), 35-48.
- Hodge, D. R. (2003). *Spiritual assessment: A handbook for helping professionals*. Botsford, CT: NACSW.
- Hodge, D. R. (2004a). Spirituality and people with mental illness: Developing spiritual competency in assessment and intervention. *Families in Society*, 85(1), 36-44.
- Hodge, D. R. (2004b). Why conduct a spiritual assessment? A theoretical rationale for assessment. *Advances in Social Work*, 5(2), 183-196.
- Hodge, D. R. (2005a). Developing a spiritual assessment toolbox: A discussion of the strengths and limitations of five different assessment methods. *Health and Social Work*, 30(4), 314-323.
- Hodge, D. R. (2005b). Social work and the house of Islam: Orienting practitioners to the beliefs and values of Muslims in the United States. *Social Work*, 50(2), 162-173.
- Hodge, D. R. (2005c). Spiritual assessment in marital and family therapy: A methodological framework for selecting between six qualitative assessment tools. *Journal of Marital and Family Therapy*, 31(4), 341-356.
- Hodge, D. R. (2005d). Spiritual ecograms: A new assessment instrument for identifying clients' spiritual strengths in space and across time. *Families in Society*, 86(2), 287-296.
- Hodge, D. R. (2005e). Spiritual life maps: A client-centered pictorial instrument for spiritual assessment, planning, and intervention. *Social Work*, 50(1), 77-87.
- Hodge, D. R. (2006). A template for spiritual assessment: A review of the JCAHO requirements and guidelines for implementation. *Social Work*, 51(4), 317-326.
- Hodge, D. R. (2007). A systematic review of the empirical literature on intercessory prayer. *Research on Social Work Practice*, 17(2), 174-187.
- Hodge, D. R. (2008). Constructing spiritually modified interventions: Cognitive therapy with diverse populations. *International Social Work*, 51(2), 178-192.
- Hodge, D. R. (2009). Secular privilege: Deconstructing the invisible rose-tinted sunglasses. *Journal of Religion and Spirituality in Social Work: Social Thought*, 28(1/2), 8-34.
- Hodge, D. R., Baughman, L. M., & Cummings, J. A. (2006). Moving toward spiritual competency: Deconstructing religious stereotypes and spiritual prejudices in social work literature. *Journal of Social Service Research*, 32(4), 211-232.
- Hodge, D. R., Bonifas, R. P., & Chou, R. J. (2010). Spirituality and older adults: Ethical guidelines to enhance service provision. *Advances in Social Work*, 11(1), 1-16.
- Hodge, D. R., & Bushfield, S. (2006). Developing spiritual competence in practice. *Journal of Ethnic and Cultural Diversity in Social Work*, 15(3/4), 101-127.
- Hodge, D. R., & Limb, G. E. (2009a). Spiritual histories and Native Americans: A mixed method validation study. *Journal of Social Service Research*, 35(4), 285-296.
- Hodge, D. R. & Limb, G. E. (2009b). Establishing the preliminary validity of spiritual eco-maps with Native Americans. *Clinical Social Work Journal*, 37(4), 320-331.
- Hodge, D. R., & Limb, G. E. (2010a). Conducting spiritual assessments with Native Americans: Enhancing cultural competence in social work practice courses. *Journal of Social Work Education*, 46(2).
- Hodge, D. R., & Limb, G. E. (2010b). A Native American perspective on spiritual assessment: The strengths and limitations of a complementary set of assessment tools. *Health & Social Work*, 35(2), 121-131.
- Hodge, D. R., & Limb, G. E. (2010c). Native Americans and brief spiritual assessment:

- Examining and operationalizing the Joint Commission's assessment framework. *Social Work*, 55(4), 297-307.
- Hodge, D. R., & McGrew, C. C. (2006). Spirituality, religion and the interrelationship: A nationally representative study. *Journal of Social Work Education*, 43(3), 637-654.
- Hodge, D. R., & Williams, T. R. (2002). Assessing African American spirituality with spiritual eco-maps. *Families in Society*, 83(5/6), 585-595.
- Hunter, J. D. (1991). *Culture Wars*. New York: BasicBooks.
- Jankowski, P. J. (2002). Postmodern spirituality: Implications for promoting change. *Counseling and Values*, 47(1), 69-79.
- Johnson, B. R. (2002). *Objective hope*. Philadelphia, PA: Center for Research on Religion and Urban Civil Society.
- Kerr, P. A. (2003). The framing of fundamentalist Christians: Network television news, 1980-2000. *Journal of Media and Religion*, 2(4), 203-235.
- Koenig, H. G. (2007). *Spirituality in patient care* (2nd ed.). Philadelphia: Templeton Foundation Press.
- Koenig, H. G., McCullough, M. E., & Larson, D. B. (2001). *Handbook of religion and health*. New York: Oxford University Press.
- Limb, G. E., & Hodge, D. R. (2007). Developing spiritual lifemaps as a culture-centered pictorial instrument for spiritual assessments with Native American clients. *Research on Social Work Practice*, 17(2), 296-304.
- Limb, G. E., & Hodge, D. R. (2011). Utilizing spiritual ecograms with Native American families and children to promote cultural competence in family therapy. *Journal of Marital and Family Therapy*, 37(1), 81-94.
- McGoldrick, M., Gerson, R., & Petry, S. S. (2008). *Genograms: Assessment and intervention* (3rd ed.). New York: W.W. Norton & Company.
- NASW Code of Ethics. (2008). Retrieved 05/01/2010, from <http://www.socialworkers.org/pubs/code/code.asp>.
- NASW Standards for Cultural Competence in Social Work Practice. (2001). Retrieved 23/02/2010, from <http://www.socialworkers.org/practice/standards/NASWCulturalStandards.pdf>.
- Nee, W. (1968). *The spiritual man*. (Vols. 1-3). New York: Christian Fellowship Publishers.
- Newport, F. (2006). Religion most important to Blacks, women, and older Americans. Retrieved 06/06/2009, from <http://www.gallup.com/poll/25585/religion-most-important-blacks-women-older-americans.aspx>.
- Pargament, K. I. (2007). *Spiritually integrated psychotherapy: Understanding and addressing the sacred*. New York: Guilford Press.
- Patterson, J., Hayworth, M., Turner, C., & Raskin, M. (2000). Spiritual issues in family therapy: A graduate-level course. *Journal of Marital and Family Therapy*, 26(2), 199-210.
- Ressler, L. E., & Hodge, D. R. (2003). Silenced voices: Social Work and the oppression of conservative narratives. *Social Thought*, 22(1), 125-142.
- Richards, P. S., & Bergin, A. E. (Editors). (2000). *Handbook of psychotherapy and religious diversity*. Washington, DC: American Psychological Association.
- Rose, E. M., Westefeld, J. S., & Ansley, T. N. (2008). Spiritual issues in counseling: Clients' beliefs and preferences. *Psychology of Religion and Spirituality*, 5(1), 18-33.
- Rothman, S., Lichter, S. R., & Nevitte, N. (2005). Politics and the professional advancement among college faculty. *The Forum*, 3(1), 1-16.
- Saleebey, D. (Editor). (2009). *The strengths perspective in social work practice* (5th ed.). Boston: Pearson/Allyn & Bacon.

- Sheridan, M. (2009). Ethical issues in the use of spiritually based interventions in social work practice: What we are doing and why. *Journal of Religion and Spirituality in Social Work*, 28(1/2), 99-126.
- Smith, C. (2003). *The secular revolution*. Berkeley: University of California Press.
- Smith, C., & Faris, R. (2005). Socioeconomic inequality in the American religious system: An update and assessment. *Journal for the Scientific Study of Religion*, 44(1), 95-104.
- Smith, E. J. (2006). The strength-based counseling model. *The Counseling Psychologist*, 34(1), 13-79.
- Taylor, R. J., Chatters, L. M., & Jackson, J. S. (2007). Religious and spiritual involvement among older African Americans, Caribbean Blacks, and non-Hispanic Whites: Findings from the National Survey of American Life. *Journal of Gerontology*, 62B(4), S238-S250.
- Tracz, S. M., & Gehart-Brooks, D. R. (1999). The lifeline: Using art to illustrate history. *Journal of Family Psychotherapy*, 10(3), 61-63.
- Ulrich, W. L., Richards, P. S., & Bergin, A. E. (2000). Psychotherapy with Latter-day Saints. In P. S. Richards & A. E. Bergin (Eds.), *Handbook of psychotherapy and religious diversity* (pp. 185-209). Washington, DC: American Psychological Association.
- Van Hook, M., Hugen, B., & Aguilar, M. A. (Editors). (2001). *Spirituality within religious traditions in social work practice*. Pacific Grove, CA: Brooks/Cole.